



Terra Variant 435

HOLMER 
exxact



07/2019

Terra Variant 435

The slurry trac for everyone.

The Terra Variant 435 is the „little brother“ of the Terra Variant 585. The extremely light liquid slurry trac is ideally suited for fertilising crops in spring and for spreading liquid slurry close to the ground.

The Terra Variant is made to the highest quality in Germany. HOLMER develops and builds its vehicles in Bavarian Eggmühl – and has almost 50 years of experience as a machine builder and partner in agriculture. Customer service, spare parts deliveries, sales – at HOLMER, you get everything from a single source and are part of a strong, innovative family.

With passion and appreciation, we work on advanced solutions to inspire you with the Terra Variant. Our machines are technologically advanced. Worldwide. For your success.

The Terra Variant 435 at a glance:

- > **Offset track driving and Terra tyres – for optimum soil preservation**
- > **16.7 t incl. slurry technology – because soil conservation begins with weight**
- > **16 m³ slurry tank – for a perfect balance**
- > **435 PS / 320 kW engine power – for suitable power reserves**
- > **Hydrostatic travel drive – for seamless travel from 0-40 km/h**
- > **Intuitive operating concept HOLMER SmartDrive – with integrated control of slurry technology**
- > **Driver assistance system HOLMER DynaProtect – only flying is gentler on the ground**
- > **Full front suspension incl. Slope support system – for optimum stability in any position**
- > **Full-pivotable three-point mount – for lowest material load**
- > **Low diesel consumption – for working economically**

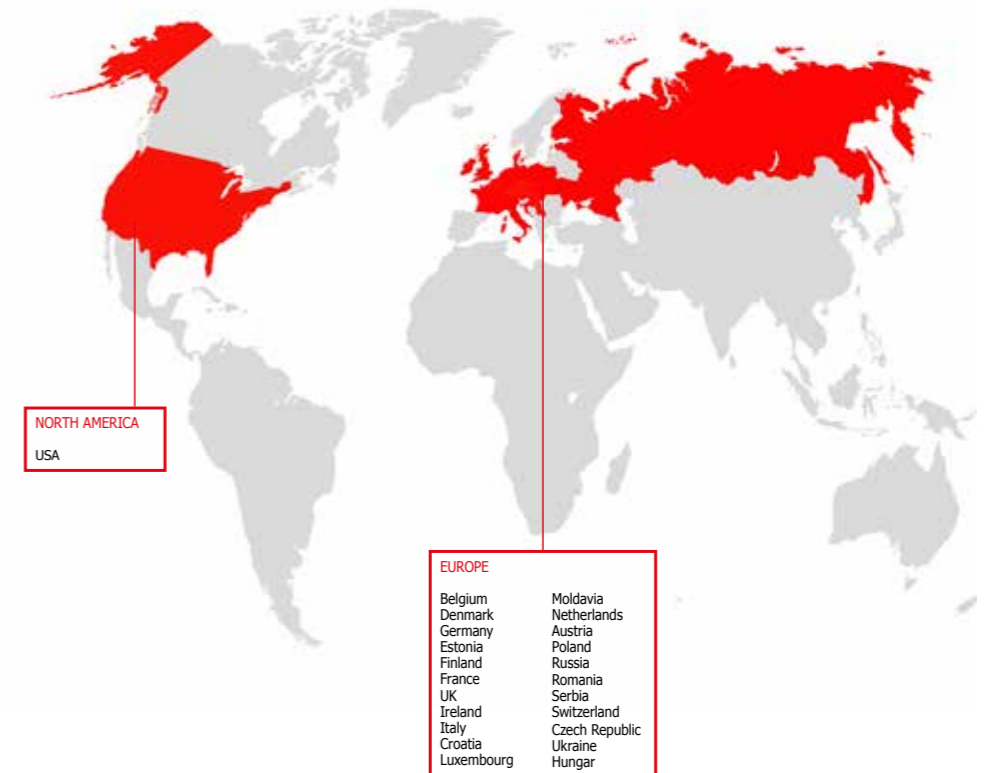

Live family.

From professionals for professionals

HOLMER has been building liquid slurry tracs for over 20 years – starting with the Terra Variant 420 with hydrostatic drive. Our experience is your success.

The Terra Variant has been put to proven international use over the past 20 years: Farmers and contractors in more than 15 countries are therefore driving the Terra Variant with success.

The clear objective in developing the Terra Variant 435 was to build a small, light vehicle that is perfectly designed for spreading liquid slurry in spring – especially in small areas. Our developers threw all their expertise into this: Intelligent designs and the use of modern, high-strength steels guarantee maximum stability and optimum material utilisation. We have also taken our suppliers up on their promise: The Terra Variant 435 uses, among other things, lighter rims, pioneering tyre technology and a new aluminum slurry pump.

Thus, the Terra Variant is not simply a machine. It is the concept for working effectively and sustainably – for everyone. This allows you to use the ever-shorter processing periods efficiently and in a soil-conserving manner.

The Terra Variant 435 developed in Eggmühl (Bavaria, Germany):

- > Sustainable overall concept – for your success
- > Consistently lightweight construction – because soil conservation begins with weight
- > Design meets functionality – perfect overview for your safety
- > Developed according to customer specifications – because you know your fields best



Working efficiently.



„The ‚little‘ Terra Variant has a lot of heart in it. We didn't make it easy for ourselves and put all components to the test. I was particularly proud when we first measured the weight: A tare weight of only 16.7 t is unrivalled and opens up new possibilities for our customers.“

Bernhard Fuchs
(Product Management)

The Trac Concept

Protecting agricultural land is our primary goal. A low vehicle weight, high rolling-over speed, a carried load (as opposed to pulled), and the right driving strategy are the key factors. The large-volume tyre completes the Trac concept. The Terra Variant 435 combines optimum soil conservation and greatest possible manoeuvrability with a perfectly coordinated volume.

Manoeuvrability

With a turning radius of only 6,80 m and two steering axles, the Terra Variant is extremely manoeuvrable. Its wheelbase of 4.26 m and the central tubular frame guarantee maximum stability in every situation.

Satisfied customers in all fields:

- > 6.80 m turning radius – for small fields
- > 2 planetary steering axles – for optimum manoeuvrability
- > 4.26 m long wheelbase – for very good stability
- > Stable central tubular frame – as the basis for maximum longevity
- > Comfortable chassis with 3rd and 4th axle for driving on roads – for your safety in road traffic

Mounting area

When working with loads, it is important that the mounting area is ideally positioned on the tractor. Only in this way, can perfect weight distribution be guaranteed – and this is the prerequisite for optimum soil conservation and driving comfort.

Sustainable and efficient work:

- > Carried loads - not pulled – the basis for all soil protection
- > 16 m³ slurry build-up – perfectly matched to the vehicle
- > Ideal weight distribution – for best driving characteristics

Being in balance.



Tyres



The Terra Variant 435 in the standard version is equipped with MICHELIN CerexBib. This brand new tyre technology allows for a low inner tyre pressure of min. 1.2 bar with a footprint of up to 0.87 m² per wheel, enabling best soil preservation.

Terra tyres for optimum soil protection:

- > Low tyre pressure – for maximum soil preservation
- > Large footprint of up to 0.87 m² per wheel with MICHELIN CerexBib 2 VF 900/60 R38 – for the prevention of harmful compaction and for optimum weight distribution
- > Low track depth – for uniform growth
- > High roll-over speed – for low soil compaction
- > Row crop tyres – for spreading in row crops

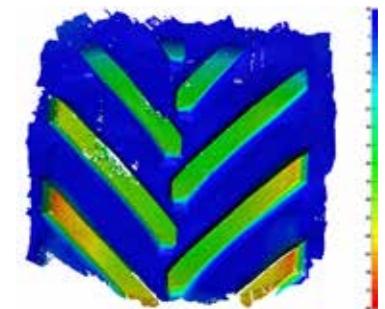

Michelin CEREXBIB 2

Diagonal steer

Offset track driving ensures that each surface is rolled over only once. Each wheel has its own track. The four wheels of equal size make the weight evenly distributed. This consistently prevents soil damage from compaction. Given the large contact surfaces of the tyres in the diagonal steer, load and traction force are transmitted over a wide surface area – with optimal slip values at the same time. This is how real soil preservation works.

The Terra Variant 435 steering modes:

- > All-wheel steering – for maximum manoeuvrability
- > Automatic steer left/right – for rolling over wide areas and stable driving behaviour on side slopes
- > Four-wheel steering – for using the multi-pass-effect during lane-in-lane rides
- > Manual steering – for independent steering of the rear axle by joystick
- > Road driving – for high road safety in public traffic



„The low weight of the new Terra Variant 435 allows us to go to our crop early – and that’s a huge advantage for us in the Spring.“

**Josef Blümel
(Blümel GmbH)**

Organic fertilisation in spring is becoming increasingly important as application periods become shorter. During the vegetation phase, the nitrogen requirement is high, so that the fertilizer applied can be used perfectly by the plants. Those who make optimum use of this time window will work in an environmentally friendly manner and thus be fit for the future.

Rapid and low-cost delivery of the fertiliser in a separate process is of crucial importance.

All the vehicles in the chain are based on the key machine – the Terra Variant. Fuel and wear costs are reduced on all vehicles throughout the entire slurry spreading system.

Therefore, the transport tankers must be optimally adapted for road transport Trucks or tractors can be used. The number of transport tankers depends on the transport distance and the path structure. In turn, the tank size of the transport tankers is oriented to the Terra Variant, whereby a wide range of solutions have been proven in practice.

The Terra Variant’s tank volume of 16 m³, combined with extremely short evacuation times of approx. 2 minutes, ensures the shortest downtimes of the feeder vehicles. Due to the small turning circle of only 6.80 m, the Terra Variant is also ideal for small fields. Due to its low weight and wide tyres, it can also be used in spring to protect the soil. This extends the effective working hours for spreading and ensures impact – with the Terra Variant optimally prepared for shortening spreading periods, particularly in the spring.

Concept

The Terra Variant has been comprehensively designed so that you are well prepared for the farming of tomorrow.

COMFORT CABIN

- > HOLMER SmartDrive – for operating comfort
 - HOLMER EasyTouch with 12.1-inch touch terminal
 - Ergonomic joystick with shortcut keys
 - Jog dial for terminal control
 - Three-point mount and tailgate control
 - Vehicle diagnostics
- > HOLMER functional armrest – for ergonomic operations
- > Automatic climate control – for a cool head
- > GRAMMER active seat – for comfortable operation

DRIVE TRAIN:

- > Hydrostatic travel drive – for stepless travel from 0-40 km/h
- > Maximum speed 40 km/h – for fast transfer
- > HOLMER DynaProtect – for a dynamically adjusted lead

REAR HYDRAULICS

- > Hydraulically swivelling three-point mount category III on both sides for the lowest material stress at 70 kN lifting force
- > Three-point mount loading and unloading – for slurry injection into growing stocks
- > 3 double acting control units; time and quantity adjustable – for high flexibility
- > Load-sensing and power-beyond – for optimum oil supply

DIESEL ENGINE

- > Mercedes Benz OM 470 LA – for exhaust gas Tier V
- > 435 PS / 320 kW – for appropriate power reserves
- > Ad-Blue exhaust gas treatment – for a clean environment

POWER HYDRAULICS

- > Load-sensing pump max. 357 l / min – for demand-driven performance requirements
- > Hydraulic supply slurry technology: Variable displacement pump Danfoss H1 P 130 with max. flow rate 313 l/min – for suctioning in idle gas

CHASSIS

- > 2 planetary steering axles – for perfect manoeuvrability
- > Hydraulically sprung swing axle – for even more driving comfort
- > Slope stabilisation system – for safety in all positions

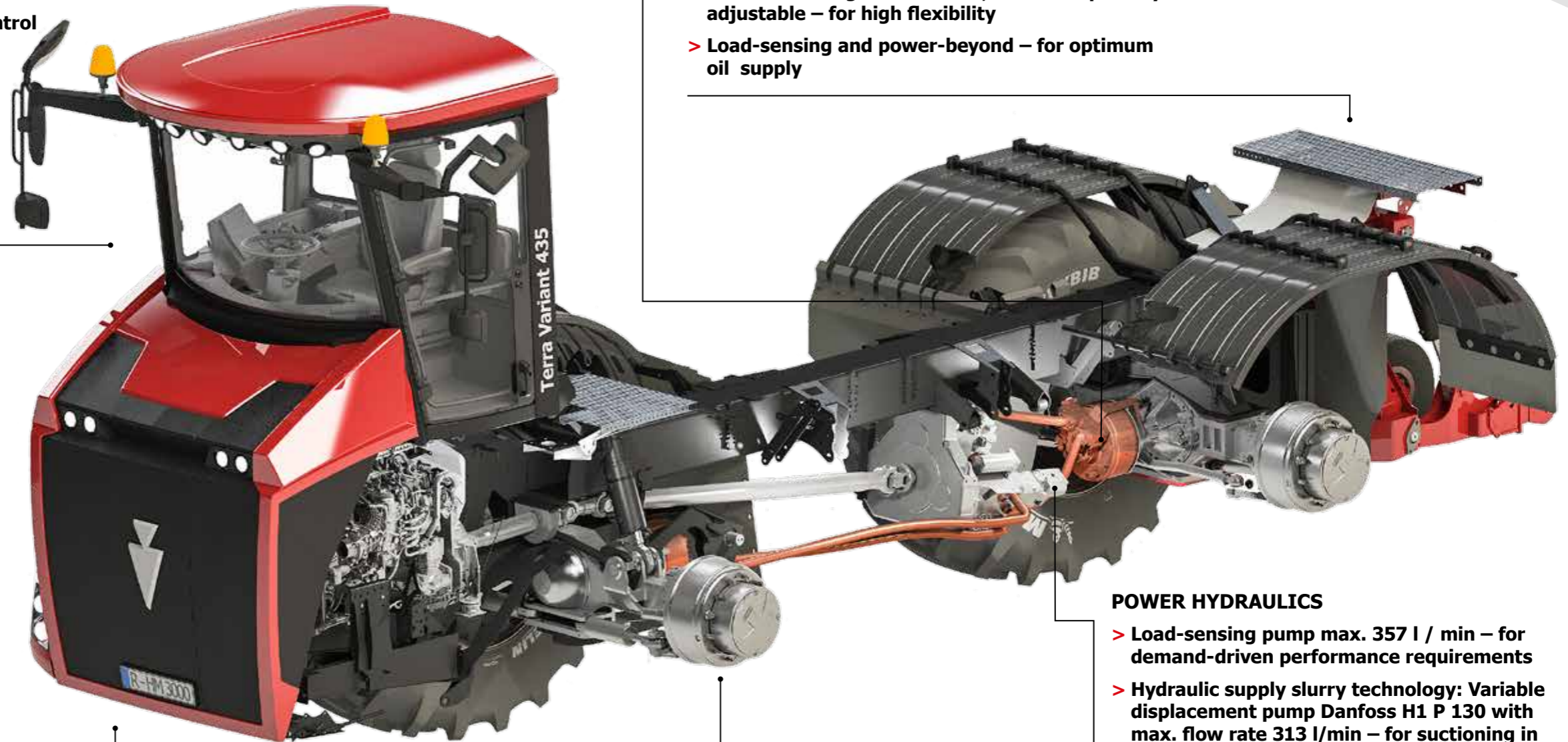

Be one with yourself.

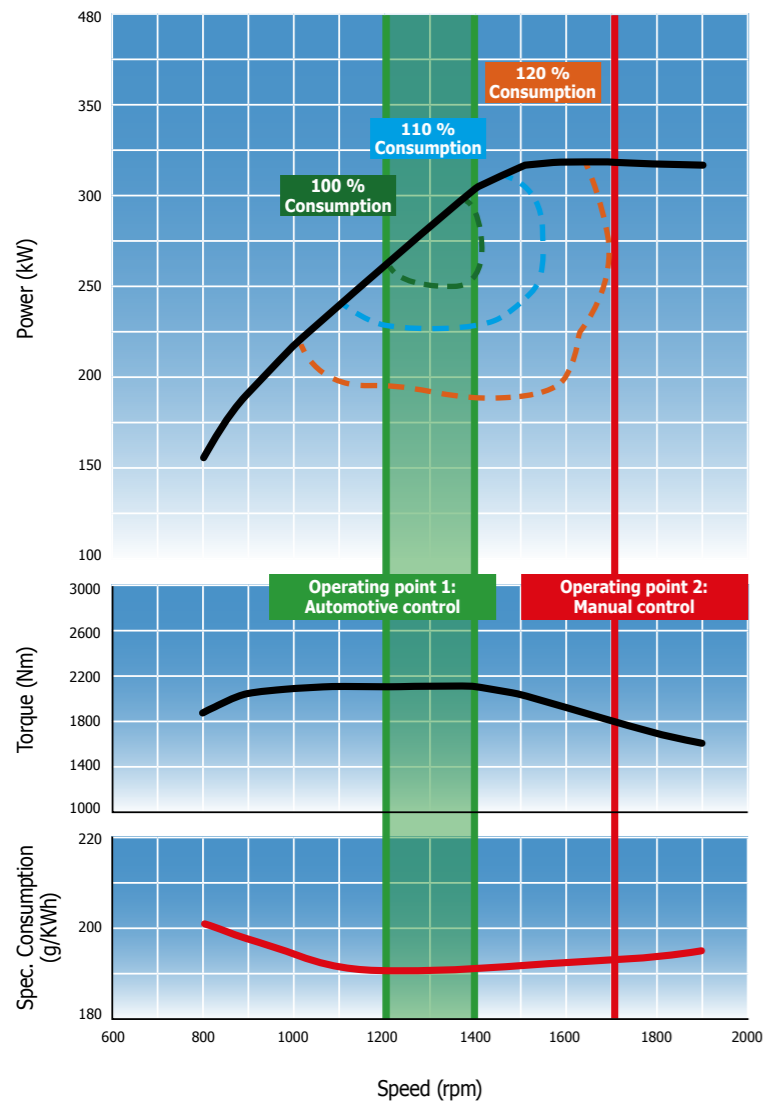

Use fuel sensibly:

The power-dependent, automotive speed control of the diesel engine makes it possible for it to always run at the optimum consumption level when working.

Driving speeds are maintained with the cruise control during field work - without the operator needing to press the accelerator.

When driving on the road, the speed of the diesel engine is automatically reduced – thus saving fuel.



Motor

Engine technology from Mercedes Benz and its low weight make the Terra Variant 435 the perfect vehicle for spring use. With 435 PS / 320 kW, attachments up to 3 t can be used without any problems and loads are supported in a way that protects the soil. The Terra Variant meets the exhaust gas standard Tier V. AdBlue ensures that nitrogen oxides generated during the combustion process are converted into pure nitrogen and water during the exhaust gas after treatment – for the sake of our environment. For regular maintenance work, access to the engine area is possible – for safety and ergonomic working conditions.

The „small“ Terra Variant:

- > 435 PS / 320 kW – for appropriate power reserves
- > Exhaust gas level Tier V – environmentally friendly
- > Optimal torque characteristics – for efficient engine performance
- > Max. torque 2,100 Nm at 1.300 rpm – for low engine speeds and low fuel consumption
- > Automotive speed control – for consumption-optimised operation
- > Low diesel consumption – for optimum cost control
- > Engine located in front of the front axle – where it is cleanest
- > Easy accessibility – for ergonomic maintenance work
- > Hydraulically reversible fan with time control – for clean cooling elements
- > Diesel and AdBlue tank caps next to each other – for fast refuelling

Organise your powers.

Drive train:

The „small“ Terra Variant has an innovative hydrostatic travel drive with independent single-axle drives, which enables stepless travel from 0-40 km/h – cardan shafts to the axles are therefore no longer required. Two separate travel drive pumps are installed on the pump transfer case for independent control of the axles. Each axle drive therefore has its own power supply.

New vehicle, new concept:

- > **Hydrostatic travel drive – for seamless travel from 0 up to 40 km/h**
- > **Two single-axle drives – for driving without cardan shafts**
- > **Large drum brakes – for your safety**
- > **Compressed air brake system optional – for towed attachments**
- > **Central lubrication – for all important lubrication points**
- > **Lubrication intervals adjustable – for individual applications**
- > **Top speed up to 40 km/h on the road – for fast transfer**
- > **Top speed up to 32 km/h in field driving – for efficient working**

DynaProtect 
Only flying is more soil protecting.



DynaProtect

Unique: With the HOLMER DynaProtect driver assistance system, soil and crop are optimally protected during slurry application. After the driver has preselected „grassland/grain“ or „row crop/stubble“, the system adjusts itself automatically.

On the level, the system guarantees even rolling of the wheels without leading – thus preventing damage to the growing crop or the turf and reducing slippage.

On a side slope on grassland, the lead of the front axle increases slightly – the vehicle is stabilised safely and the ground is protected to the maximum at the same time.

On side slopes in row crops, the lead is further increased in order to guarantee directional stability and thus protect the crop.

If reverse gear is engaged, the leading gear automatically changes to the rear axle. This makes driving safe and easy and guarantees the smallest turning radiuses. All settings are dynamic and depend on the information that the slope sensor reports live.

In road driving mode, a consistent zero lead is automatically set in order to protect the tyres and minimise fuel consumption.

Stay ahead.



Front axle suspension and slope support

Safety and consistently high driving comfort is ensured by the unique HOLMER front axle suspension with slope support and automatic levelling control. In connection with the wheelbase of 4,26 m and the wide Terra tyres, the Terra Variant easily masters slopes with maximum driving stability.

Safety and driving comfort in all positions with the Terra Variant:

- > Fully automatic and stepless level control – allowing operators to concentrate on their tasks
- > Spring hardness adjustable in three steps – to adapt to local conditions
- > Floating axle with all degrees of freedom – for maximum terrain adaptation
- > Lockable slope supports – to adapt to local conditions
- > Active suspension even with locked slope support – for ideal driving comfort even on slopes



Be sure.



Three-point mount

The fully hydraulically pivotable rear power lift of the Terra Variant has been specially designed for the professional spreading of fertiliser. Only the Terra Variant has this unique technology.

The three-point mount which is suspended on the main frame via a two pivot cylinder arranged transversely at the bottom features fully automatic pivoting to the left and right. All the connection points between the vehicle and the attachment are always in a straight line of traction thanks to the fully pivoting frame, even in diagonal steer mode. This allows the material to optimally absorb the forces during slurry application – for perfect durability of the components.

A loading or unloading system is integrated as standard for slurry injectors. By pressing a button on the terminal of the attachment, the driver can either pressurise the attachment in dry conditions or relieve pressure in wet conditions.

Unique for self-propelled machines:

- > Fully tiltable three-point mount – for maximum stability
- > Three-point mount category III – for attachments of up to 3 t
- > Straight-acting forces – for stress-free use and thus the longevity of all assemblies
- > 3 double acting control units; time and quantity adjustable – for absolute flexibility
- > Load-sensing and power-beyond – for optimum oil supply
- > Standard loading and unloading – for slurry injection into stationary stock
- > Three-point mount freewheel over the terminal easy to adjust – for lowest wear
- > Integrated into the central lubrication system – for maintenance free work
- > Top link in category 3/4 – perfectly aligned to attachments
- > Safety hook or ball eyes can be selected for lower links – for various attachments



Keep promises.

„As a mechanic, I'm always on-site at the customer's premises. I help in difficult situations and also have an open ear for needs and criticism. I can pass on these suggestions and my experience directly to the development department at HOLMER – a great feeling when the finished result can be seen. I'm looking forward to working with the Terra Variant 435.“

**Richard Köllner
(Customer Service)**



At HOLMER, there are 400 employees worldwide working every day to make our machines even better for you. From development to customer service, everything at HOLMER comes from a single source. The cooperation is distinguished by progress and passion. Our success is a team achievement, which is why we are a technological leader. Worldwide. For your success.

Illumination

The illumination concept of the Terra Variant turns night into day. This also ensures optimal visibility during night-time work. The operating range of the machine is illuminated up to 100% by max. 31 LED headlights. This guarantees maximum safety during suctioning or when monitoring the attachment – especially at night.

More light, more safety:

- > Perfect lighting of the work area – for your safety
- > Max. 31 LED headlights with up to 3,400 lm – for optimum illumination on the field and road
- > Standard 4 x 1,950 lm powerful LED low-beam and high-beam headlines, including daytime running light rings – for road driving comfort



Always keep ahead.



Cabin

The dynamic design makes the Terra Variant 435 unique – edged, manly, powerful. The driver has the perfect all-round view because of the bonnet with frontal slope, the sideward suction pipe and the integrated exhaust silencer – for even more safety on field and road. The tried and tested HOLMER Comfort Cabin II also ensures comfortable machine operation around the clock on the Terra Variant 435 – for satisfying work.

After all, the operator is our priority:

- > **Perfectly clear vision – for your safety on the field and road**
- > **Operator oriented controls – for ergonomic working**
- > **Powerful climate control and tinted thermal insulation glass – for a cool head**
- > **Hydrodynamic cabin suspension – for optimum driving comfort**
- > **Excellent sound insulation with only max. 63 db volume – for operating comfort**
- > **Spacious layout with storage – for personal freedom**

Have profile.

GRAMMER active seat

The GRAMMER active seat, which has been specially designed for HOLMER, ensures additional driving comfort for use over long periods of time. It automatically adjusts itself to the driver's weight, dampens and ensures a comfortable climate through active seat ventilation. In conjunction with a pneumatic lumbar support and the active reduction of bumps, the driver remains relaxed and highly concentrated on the work whilst HOLMER provides maximum driving comfort for the highest demands.

Our experience for your health:

- > Specially built for HOLMER – because you are the focus of our developments
- > Active seat ventilation – for maximum temperature control
- > Heated seating – for cold working days
- > Active reduction of bumps – for your comfort

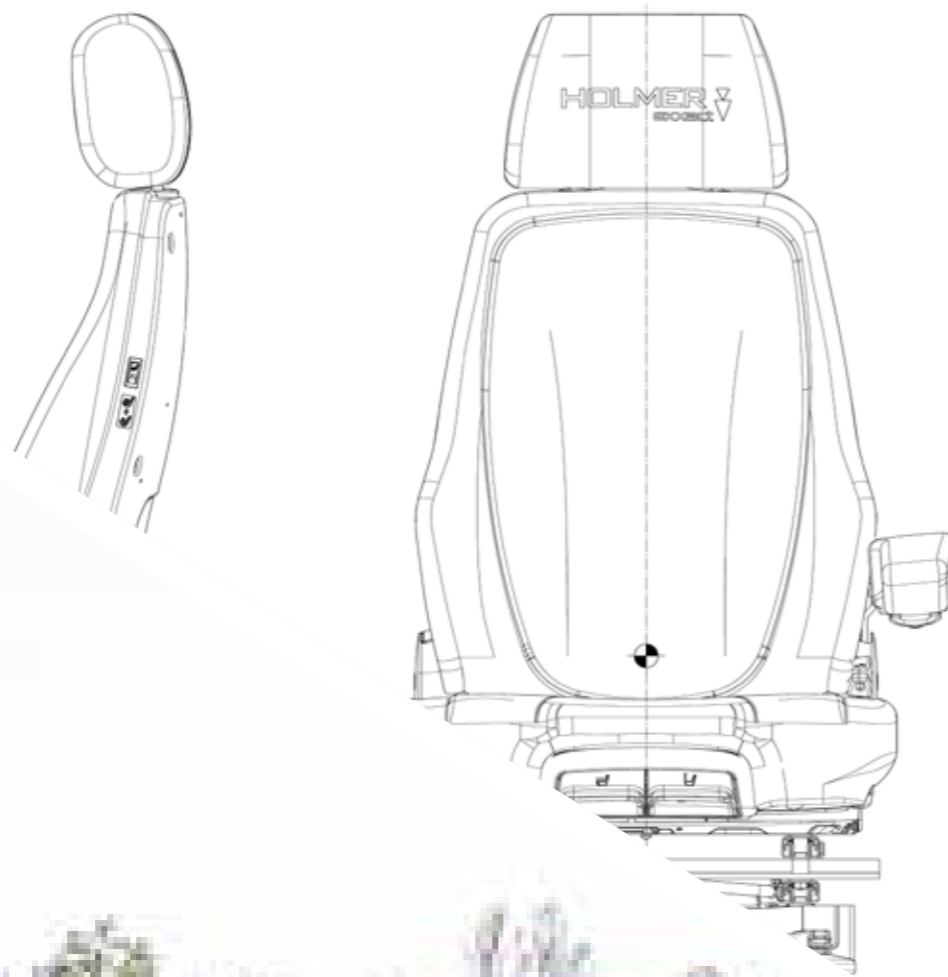

Show strength.

HOLMER SmartDrive

HOLMER SmartDrive is the intuitive operating concept for HOLMER machines. The combination of touch terminal, joystick, jog dial and three-point control unit ensures that every desired function is quickly and easily accessible. Freely programmable keys and shortcuts ensure comfortable working – because the driver is our priority.

Networking through interfaces

Assembly functions and order management are displayed directly in the HOLMER EasyTouch terminal. In addition, an ISOBUS interface for data exchange is integrated. The signal socket enables the operation of additional devices such as catch crop shakers. Via a speed and hoist signal, it is thus possible to integrate these devices into the normal workflow.

The operator in focus:

- > **Intuitive operation – for easy and safe operation**
- > **HOLMER EasyTouch 12.1-inch touch terminal – all information at a glance**
- > **Operation of slurry technology fully integrated in the HOLMER EasyTouch – for maximum ease of operation**
- > **Ergonomic multi-function arm rest with jog-dial and joystick – for comfortable vehicle operation**
- > **Orientation of all controls to the operator – since the operator and machine are one unit**
- > **Vehicle diagnostics – for speedy assistance**



Everything
under control.

Driver assistance systems

We are constantly working on technical solutions to support and facilitate the operator's workload as much as possible – so they can focus on their actual task of delivering outstanding work.

The work facilitation of the future already here today:

- > **GPS steering system** – for the most precise closing-up
- > **HOLMER TerraControl light-headland management** – for optimal reversing
- > **Data management** – for easy reporting
- > **ISOBUS connection** – for maximum connectivity



GPS

Through precise closing-up, track guidance systems relieve the operator's workload, save operating materials and preserve resources. In addition, tracks that have already been processed can be detected to the exact centimetre and re-used for subsequent machining operations.

You have the choice:

- > **GPS through Trimble Ready**
- > **AB Line** – for easy parallel driving
- > **A+-line** – for stubble breakage at a preselected angle to the direction of working
- > **Adaptive curve** – for closing-up driving in contour mode
- > **Identical curve** – for driving around obstacles



Have the overview.



The driving comfort in the Terra Variant is outstanding. And with its extreme manoeuvrability, it's also fun to work on small surfaces."

**Patrick Gottswinter
(Blümel GmbH)**

As a light and manoeuvrable vehicle, the Terra Variant 435 fully demonstrates its strengths in the field. Thanks to its extremely small turning radius, it can also be used perfectly in small-structured areas – and it helps to make optimum use of tight time windows by quickly processing the fields. Particularly in the Spring, the low net weight of the Terra Variant 435 is an unbeatable advantage when it comes to protecting the soil when driving into stands. Thanks to the coordinated power reserves, travel speeds of 13 km/h can be achieved when spreading liquid slurry close to the ground. At the end of a working day, the Terra Variant looks back on remarkable results: The small Terra Variant creates over 1,000 m³ of slurry in one working day – in a small-structured area.

Always be ahead.



**WIR WISSEN
WAS DRIN
IST...**
...Nährstoffmessung
an Bord!



ZUNHAMMER G M B H
GÜLLE-TECHNIK

Slurry technology

The Terra Variant with tried and tested ZUNHAMMER slurry equipment: The answer to today's and tomorrow's challenges of spreading slurry for everyone. No matter whether it is high mineral fertiliser prices, stricter regulations for spreading and environmental protection, or the resulting shorter processing periods during the spreading of valuable organic fertilisers, the Terra Variant saves passages and work steps, thereby reducing plant production costs. In connection with individually combinable attachments, the Terra Variant works with valuable organic fertilisers in plant stocks or stubble, while being powerful, environmentally friendly and soil-friendly at the same time. In doing so, the Terra Variant concept sustainably saves soil structure and plant stocks.

The Slurry equipment of the Terra Variant 435 at a glance:

- > 16 m³ tank volume – for perfect balance
- > VOGELSANG pump system – for shortest extraction times of approx. 2 min.
- > Side suction – for perfect visibility and safety
- > Straight line conduit – for low flow losses
- > Modular principle with the „big brother“ Terra Variant 585 – for fast spare parts supply
- BODY CONTROL**

Concept Slurry technology

Short distances and optimum line diameters are the basis for maximum efficiency in suction and pumping processes on the Terra Variant.

SUCTION PIPE

- > GfK intake pipe – for additional weight reduction
- > Intake pipe pivotable laterally through 158°, 5.70 m long – for a maximum transfer overreach and for bridging trenches and hedgerows
- > Intake pipe with automatic folding feature via joystick – to facilitate the operator's work optimally
- > NW 250 mm with specially adapted guide – for minimal pressure loss in the system
- > Intake of fluid at idle speed at 800 rpm/min – to save fuel
- > Filling shut-off automatically – to ensure clean working
- > Tank emptying via suction arm possible – against separated slurry in the feeder

BODY CONTROL UNIT

- > Fully automatic control of spreading rate – for precise spreading result
- > Prepared for ZUNHAMMER VAN-Control – for precise recording of nutrients

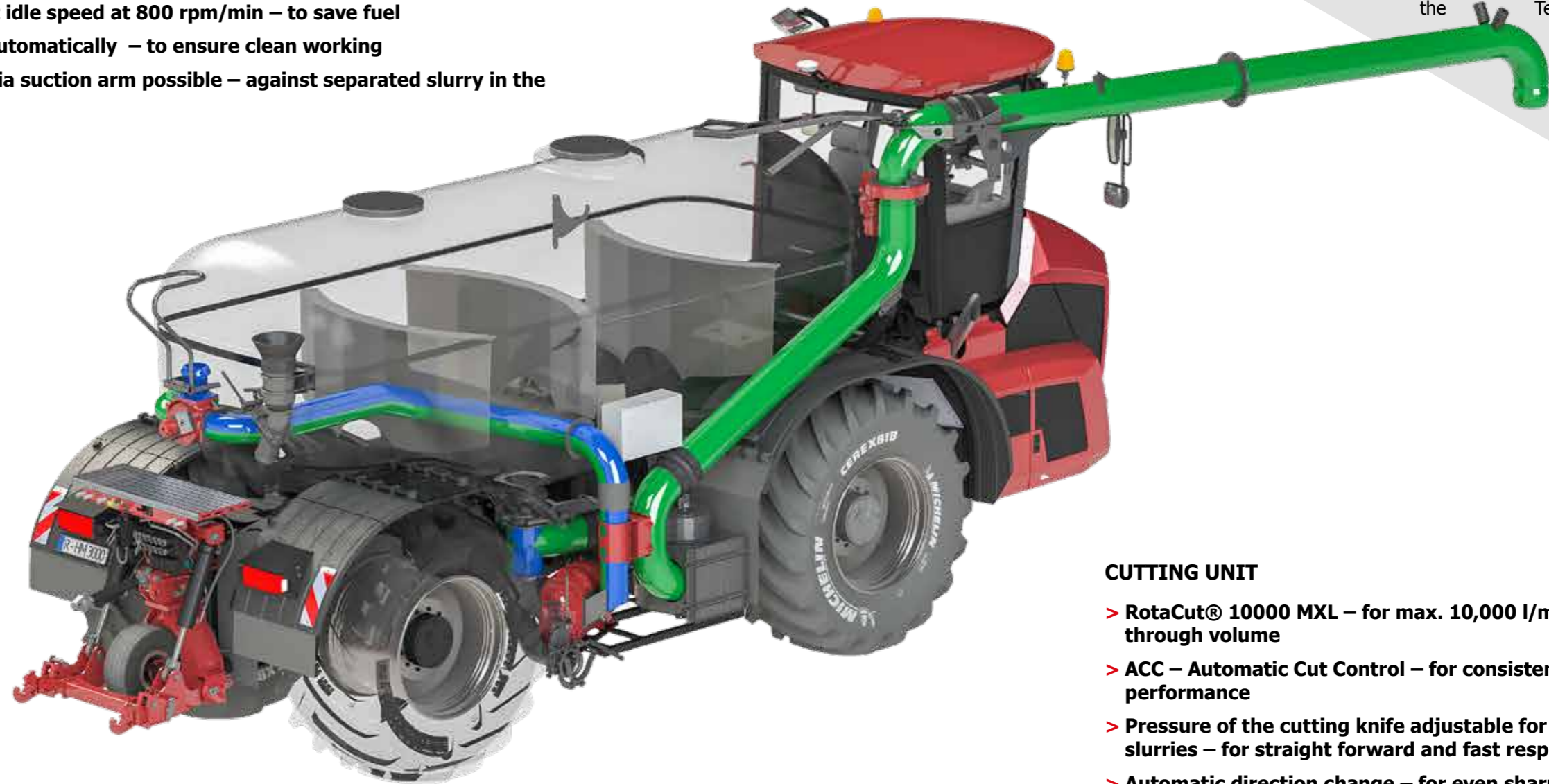

PRESSURE LINES

- > NW 200 mm – for maximum dosing accuracy
- > Integrated 3-way valve and 2 hydraulic slides – for controlling the slurry flow
- > Line routing through the GfK tank – for lowest flow losses
- > Hydraulic Drop Stop – for precise control of attachments

CUTTING UNIT

- > RotaCut® 10000 MXL – for max. 10,000 l/min flow-through volume
- > ACC – Automatic Cut Control – for consistent cutting performance
- > Pressure of the cutting knife adjustable for various slurries – for straight forward and fast response
- > Automatic direction change – for even sharpness of blade pairs
- > Hydraulic stone chute – for easy emptying of the RotaCut®

ROTARY PISTON PUMPS

- > VOGELSANG VX 186-368 QD in aluminium design – for quickest filling times of about 2 min.
- > Powerful max. 9.000 l/min output – for reliable, high suction and pumping capacity
- > Control of slurry spreading and output by joystick – for easy operation

Delivering performance.

Have passion.



Pump technology

The tried and tested VX 186-368 QD high-performance rotary piston pump from VOGLESANG guarantees reliably high suction and pump speeds of up to 9,000 l/min. In this way, 16 m³ of liquid slurry is suctioned in about two minutes.

Since it depends on the optimum pump:

- > Two-stage hydraulic motor directly on the rotary piston pump – for optimum suction and higher spreading volumes
- > HiFlo® pistons and a standard quick-service version – for long running times, low maintenance costs and minimal pulsation

The Terra Variant is fitted as standard with the VOGELSANG cutting unit RotaCut® 10000 MXL for maximum protection of the slurry pump. Fibres or foreign objects such as grass, straw or stones, are reliably cut or separated. The high throughput capacity of the cutting screen also ensures a cavitation-free run of the rotary piston pump during suction.



RotaCut® cutting unit including sieve



High-performance rotary piston pump VX 186

Be there.

HOLMER Service

Customer-oriented, reliable, competent, fast – the convincing performance of the Terra Variant is the continuation of its consistent service.
From the individual service check to the 24-hour hotline, we are always there for you.

- > **28 service partners in the German-speaking world and our own HOLMER service staff – for you on site for the fastest service**
- > **24-hour service hotline – always there for you**
- > **New logistics centre across 7,500 m² – for a perfect supply of spare parts**
- > **24-hour dispatch of spare parts during the operating time – so you can work safely**
- > **The entire range of spare parts can be conveniently ordered on the online shop – available at any time**
- > **Free, comprehensive training programme – so that you are well prepared**
- > **Terra Variant PowerCheck – individual service offers for best operational safety**
- > **Long service intervals of up to 750 operating hours – for low maintenance costs**



Used machines

Thanks to the excellent processing quality „made in Germany“ and the use of high quality components, the Terra Variant retains its value over many years. The demand for used machines is also correspondingly high.

The high value stability and low running costs ensure success for contractors and communities.

Are you looking for a HOLMER hero?
Then get in touch with us!

Be stable.

Technical data

Engine	Mercedes Benz OM 470 LA stage V
Cylinder	R-6
Piston displacement	10.7 l
Rated engine speed	1,700 rpm
Rated power at 1,700 rpm	320 kW/435 PS
max. torque at engine speed 1,200 rpm	2,100 Nm
	Automatically reversible fan
Fuel tank capacity	approx. 640 l
AdBlue tank capacity	approx. 95 l

Travel drive	
Hydrostatic travel drive	HOLMER DynaProtect stepless 0-40 km/h
Final speed	up to 40 km/h at street drive up to 32 km/h at field drive depends on country-specific regulations
All-wheel drive	permanent

Axles	2 planetary steering axles incl. axle drive
Differential locks	Front & rear axle pneumatically switchable
Axle suspension with integrated slope compensators	Independently suspended front axle beam: Hydraulic suspension incl. level control Hydraulic support for side slope stability

Chassis	
Steering modes	All-wheel steering, four-wheel steering, crab steering

Tyres	
	Ultraflex tyre technology VF 900/60 R 38 CFO+ 193 A8 TL CerexBib2
	VF 580/85 R 42 CFO+ 183 A 8 TL CerexBib2 (outer width 2.55 m)
	Tyres for row distance 75 cm (track width 2.25) VF 580/85 R42 CFO+ 183 A8 TL
	CerexBib IF 1000/55 R32 CFO 188 A8 TL (outer width 3.30 m)

Brakes	
Service brake	Hydraulic disk brake
Parking brake	Spring-loaded multi disk brake

Hydraulic system	
Hydraulic tank capacity	170 l
Load-sensing max. delivery rate	357 l/min

Power hydraulics (Depending on equipment)	
Variable pump (slurry superstructure)	Danfoss H1 P 130
max. pressure	350 bar
max. delivery rate at 1,700 rpm	313 l/min

Rear hydraulics	
Category	KAT III
Lifting capacity	70 kN

Functions	Lifting, lowering, loading/unloading, hydraulically pivotable on both sides
Rear connectors	3 double-acting control units with floating position Time and volume control
External actuation	Rear button
Interfaces	ISOBUS Interfaces Signal socket with speed signal and linkage position
Power supply	24 V alternator 150 A 12 V alternator 70 A

Cabin	
	Panorama glazing and hinged window Hydrodynamic cabin suspension Automatic climate control Stereo CD radio with Bluetooth hands-free system and DAB+ Three-point mount control element Hydraulic pivot for servicing GRAMMER active seat
Intuitive operating concept HOLMER SmartDrive	12.1" touchscreen terminal HOLMER EasyTouch Multifunctional arm rest with joystick, jog-dial for shortcut keys Integrated operating of three-point mount functions integration of the control of the slurry technique into the HOLMER EasyTouch

Illumination	
Headlights	2 x dipped-beam lights LED (1,950 lm) with angel eyes 2 x high-beam headlights LED (1,950 lm) with angel eyes
Work lights	4 x LED (3.400 lm) bonnet 4 x LED (2.500 lm) cabin roof, front, close-range 2 x LED (2.500 lm) cabin roof, rear 4 x LED (3.400 lm) cabin roof, front, distance-range 2 x LED (3.000 lm) mudguard, front

Central lubrication system	BEKA-MAX, electronically controlled intermittent lubrication and manual operation adjustable via HOLMER EasyTouch
-----------------------------------	---

Dimensions	
Total length with three-point mount	9.67 m
Width	3.00 m bei 900/60 R 38
Height	3.99 m
Ground clearance	4.26 m
Smallest turning circle	6.80 m

Optional equipment:	
	2 x LED (3.400 lm) cabin roof, sideways 2 x LED (3.000 lm) mudguard, rear Reverse camera for superstructure Compressed air brake for coupled devices HOLMER TerraControl light headland management Portable cool box



Technical data Slurry technology



ZUNHAMMER Gülletechnik equipment	
Superstructure	Permanently mounted tank with 16 m ³ capacity Lightweight GFK tank with outlet sump 2 transverse baffle boards with overflow Visual and analogue fill-level display
Slurry computer controls	Slurry computer integrated into HOLMER EasyTouch terminal ISOBUS interface for task controller with job management Automatic speed regulation for suction Memory function for performance values Integrated operating concept with joystick
Suction system	Sideways docking system DN 250 Length 5.70 m reach 158° pivot to the side, hydraulically folding Integrated folding mechanism Automatic shut-off of the filling process Pneumatic valves for suction pipe emptying Oversuction procedure when stationary 800 rpm
Line system	Suction lines: NW 250 mm (10") Pressure lines: NW 200 mm (8") Feeder DN 250 (10") hydraulically controlled, lateral Three-way valve DN 200 (8") hydraulically controlled Suction connection DN 150 (on the right side) with shut-off valve
Illumination	4 x LED (2,500 lm) on light hoists, rear 1 x LED (2,500 lm) suction pipe
Camera	Reverse camera on superstructure
Slurry pump	Reversible rotary piston pump, emptying of tank via suction pipe possible
Type	VOGELSANG VX 186-368 QD Quick-Service design with HiFlo® pistons
Pump output	max. 9,000 l/min stepless regulated
Drive	Hydrostatic; hydraulic engine mounted directly to the pump
Cutting unit	
Type	Vogelsang RotaCut® MXL 10000
Flow-through volume	max. 10,000 l/min
Drive	hydraulic
Chopping technology	Interchangeable cutting blades made of cutlery steel ACC-Automatic Cut Control for consistent pressure from the cutting blade Adjustable pressure Auto-reverse function with automatic rotation direction change Partical separator with hydraulic rock-catcher feeder
Optional equipment	
	Suction connection NW 150 right side with shut-off valve Dosing unit for nitrification inhibitor VAN control for nutrient-controlled slurry injection

Subject to changes for the purpose of technical progress; approved by TÜV and the employer's liability insurance association; meets the CE requirements. Equipment depends on country-specific regulations.



Go your own way.



07/2019

HOLMER Maschinenbau GmbH
Regensburger Straße 20
84069 Schierling/Eggmühl

TEL.: +49 (0) 94 51/93 03-0
FAX: +49 (0) 94 51/93 03-31 32 00

info@holmer-maschinenbau.com
www.holmer-maschinenbau.com

HOLMER 
exxact